



Environment and
Climate Change Canada

Environnement et
Changement climatique Canada

Canada



CanESM5

The Canadian Earth System Model version 5

**Neil Swart, John Scinnoca, Jason Cole, Slava Kharin,
Mike Lazare, Knut von Salzen, Vivek Arora, Duo Yang,
Oleg Saenko, Nathan Gillett, Jim Christian et al.**

Canadian Centre for Climate Modelling and Analysis

NEMO users meeting

Toulouse

12 October 2018

Stable of models at CCCma

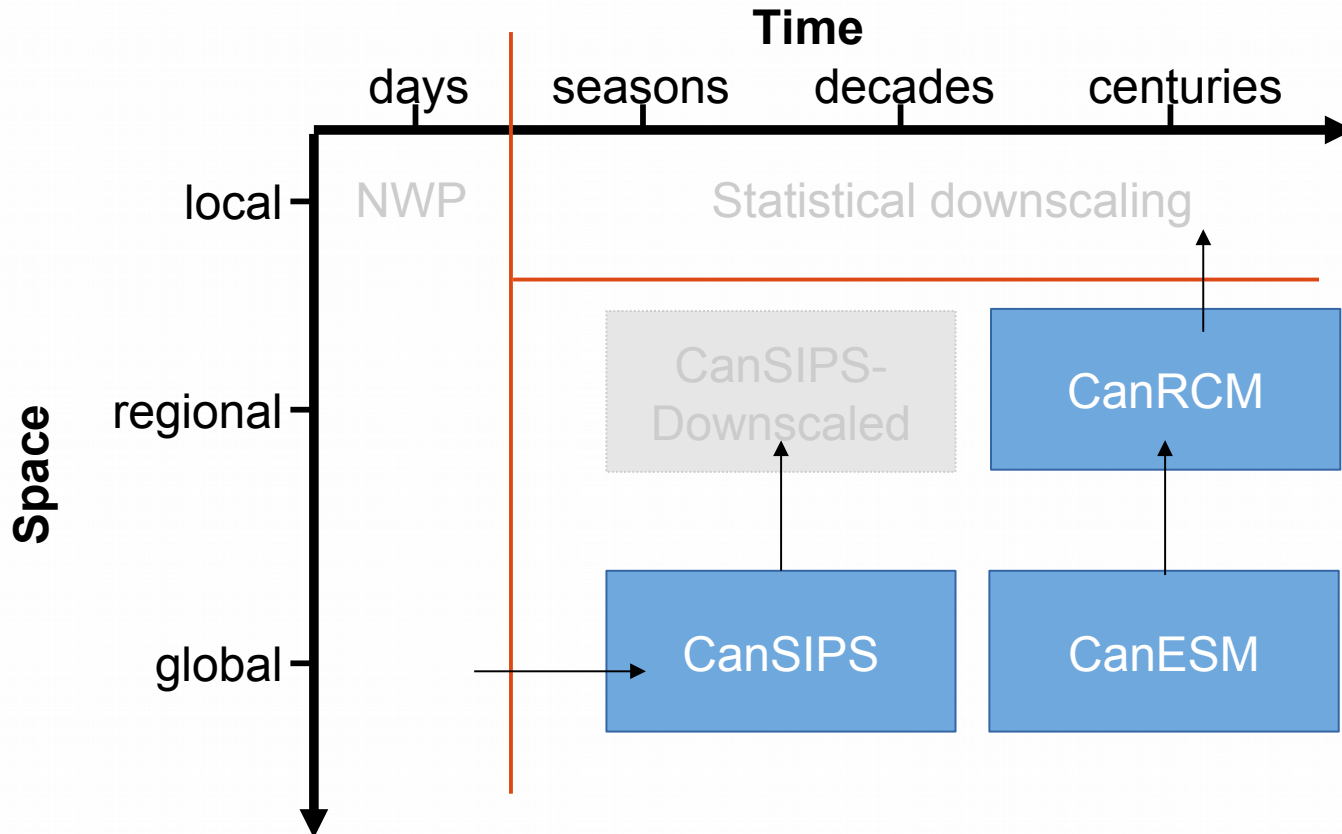

Models share a common framework and components

Page 2 – October 9, 2018



From CanESM2 to CanESM5

CanESM2 (CMIP5)

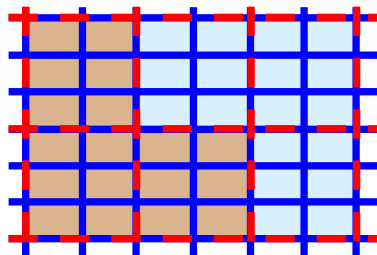
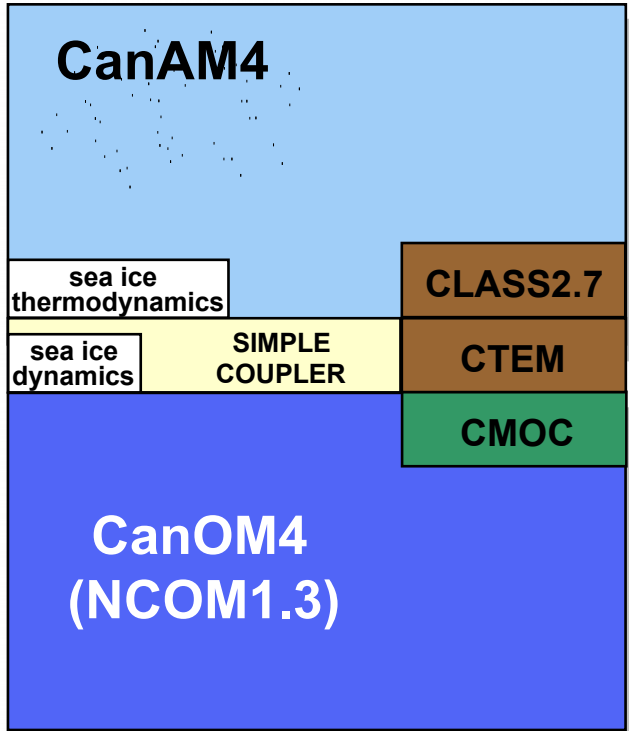

CanESM5 (CMIP6)

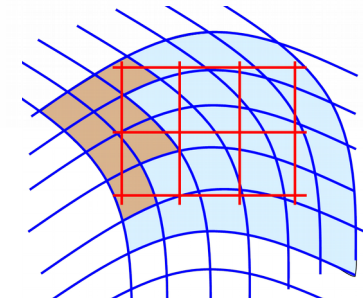
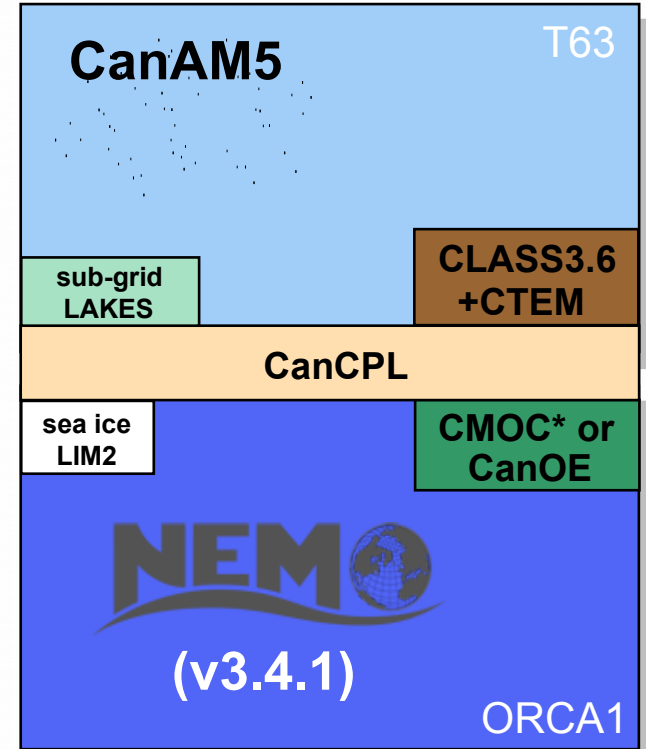

NEMO configuration

ORCA1 nominal 1°, refining to 1/3° in tropics, 46 levels

LIM2 sea-ice model, CanAM albedo

CCCma physics:

- Modified Gent McWilliams coefficient
- Lee wave mixing parameterization
- Parameter tuning

CMOC and CanOE biogeochemistry

15 years/day coupled, >100 years/day ocean only on XC40s.

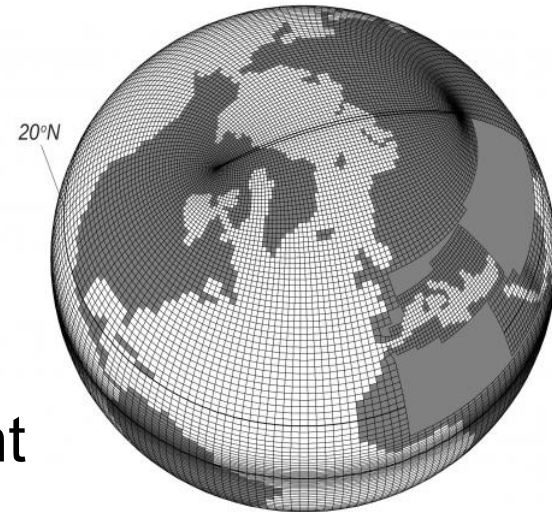

V3.4.1



CanESM5 biogeochemistry

Canadian Model of Ocean Carbon (CMOC)

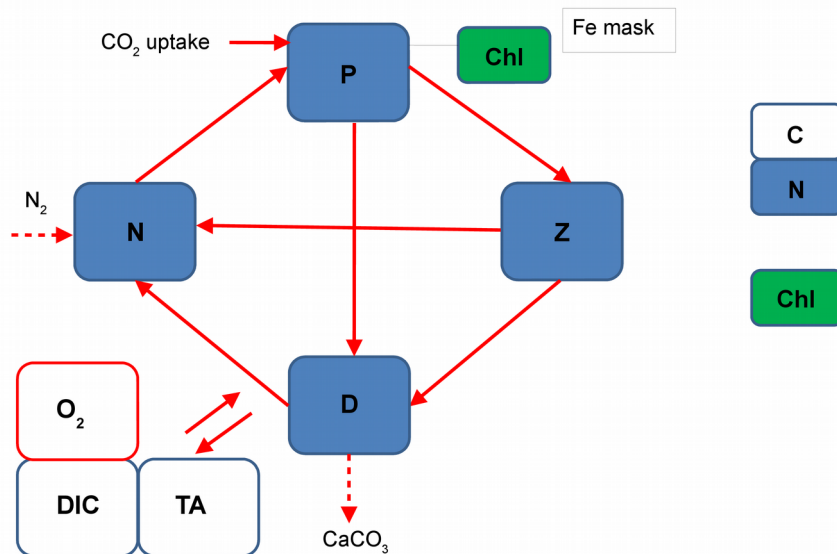

Canadian Ocean Ecosystem (CanOE)

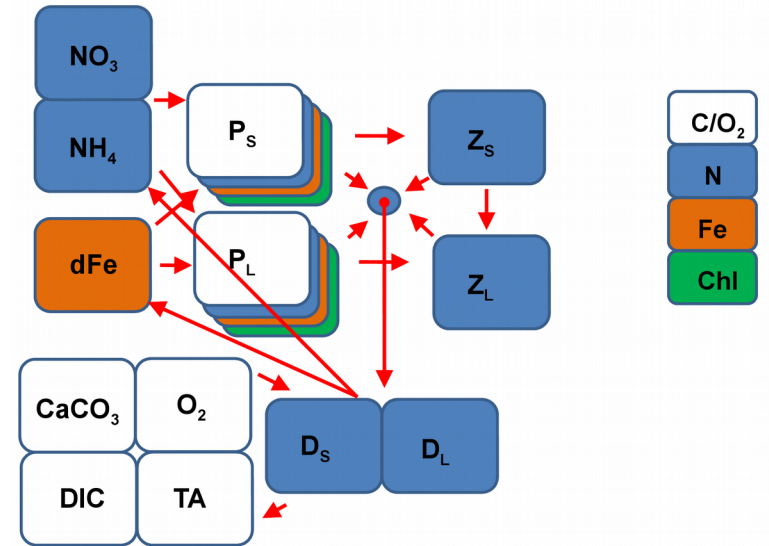

CanESM5 validation: surface temp

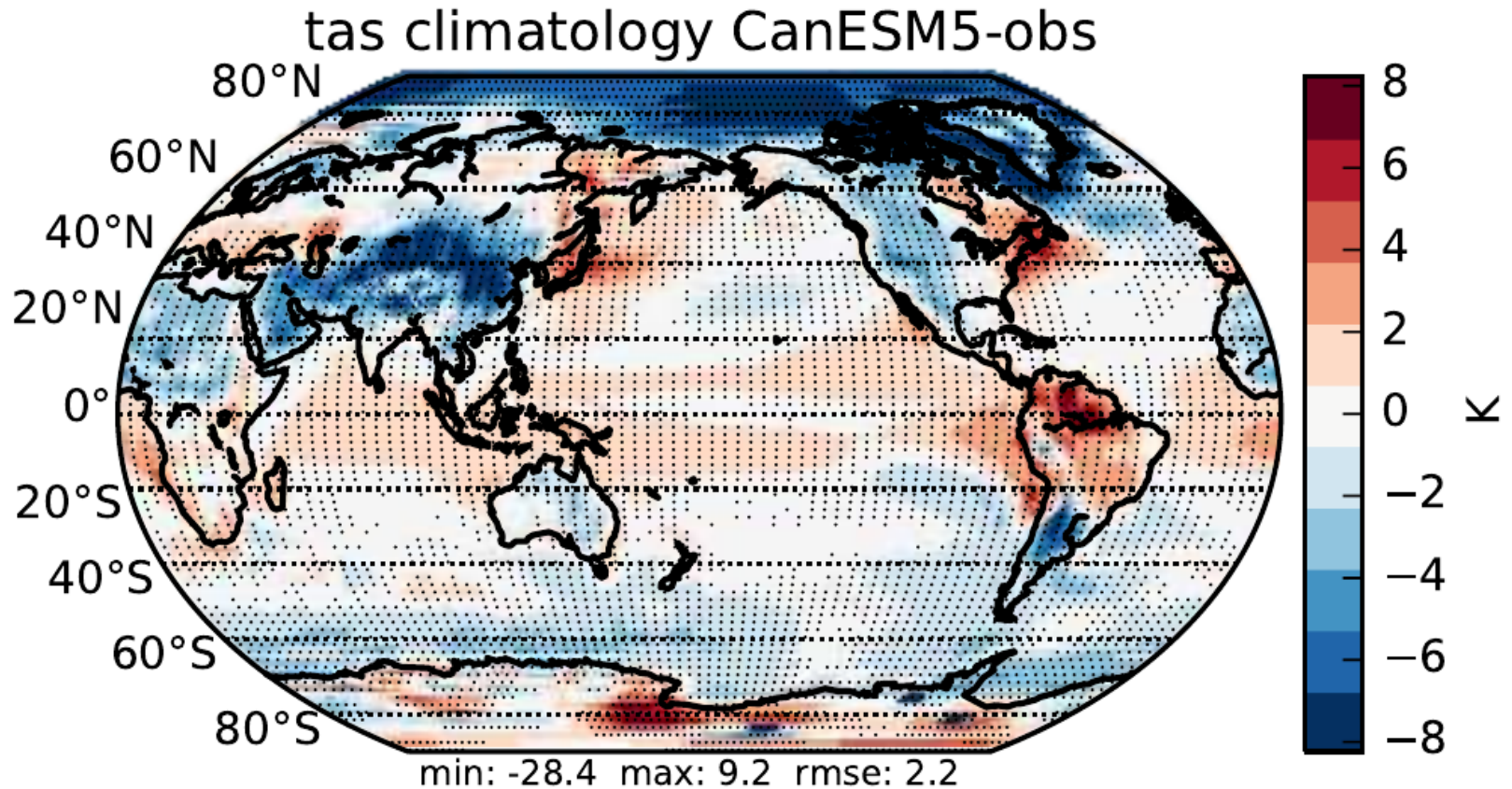

CanESM5 validation: sea-ice

Annual cycle of NH ocean sea ice volume

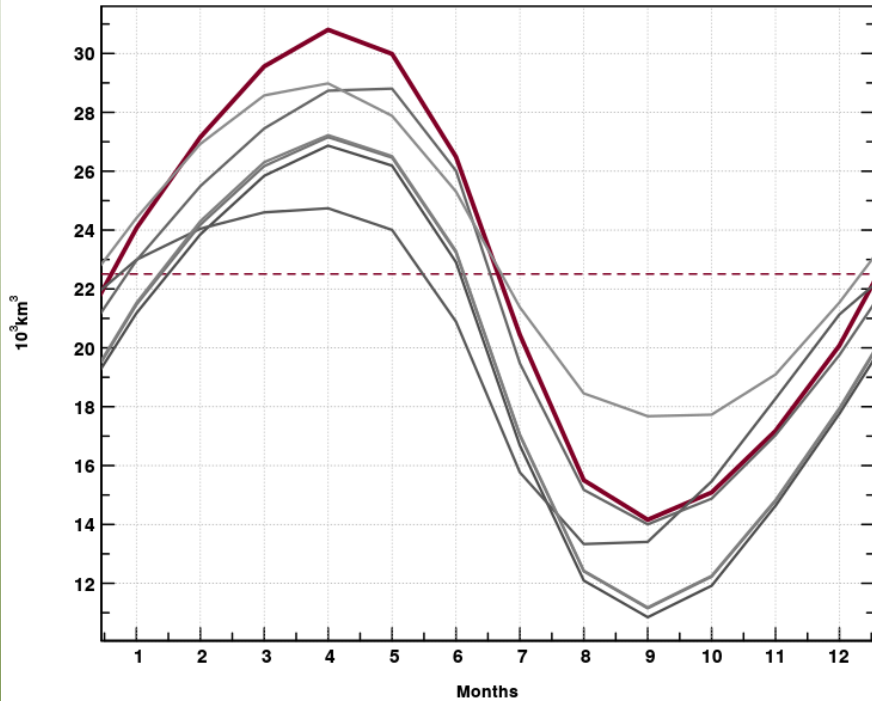

Annual cycle of NH ocean sea ice area

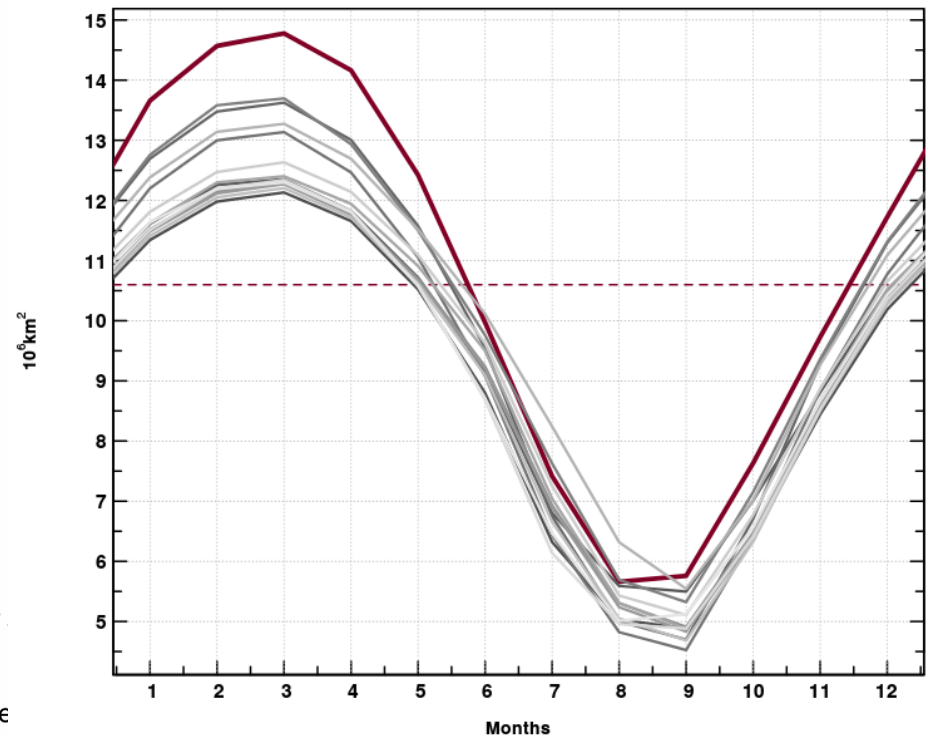

CanESM5 validation: ocean physics

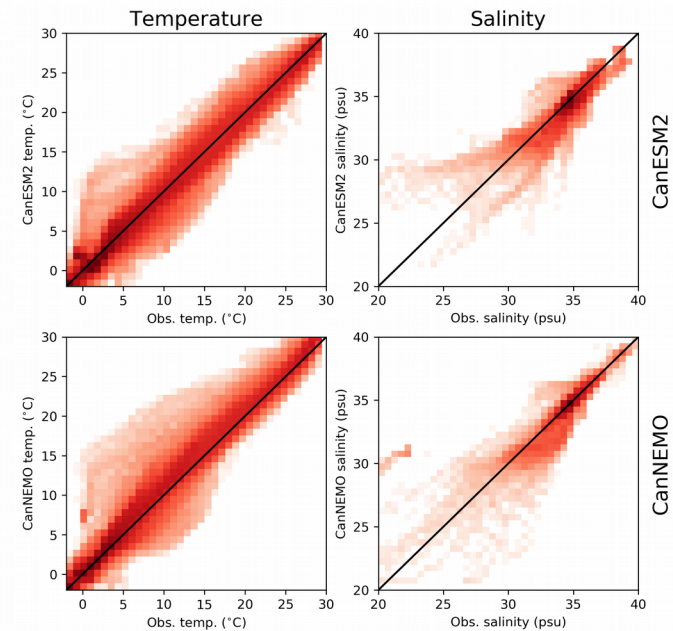
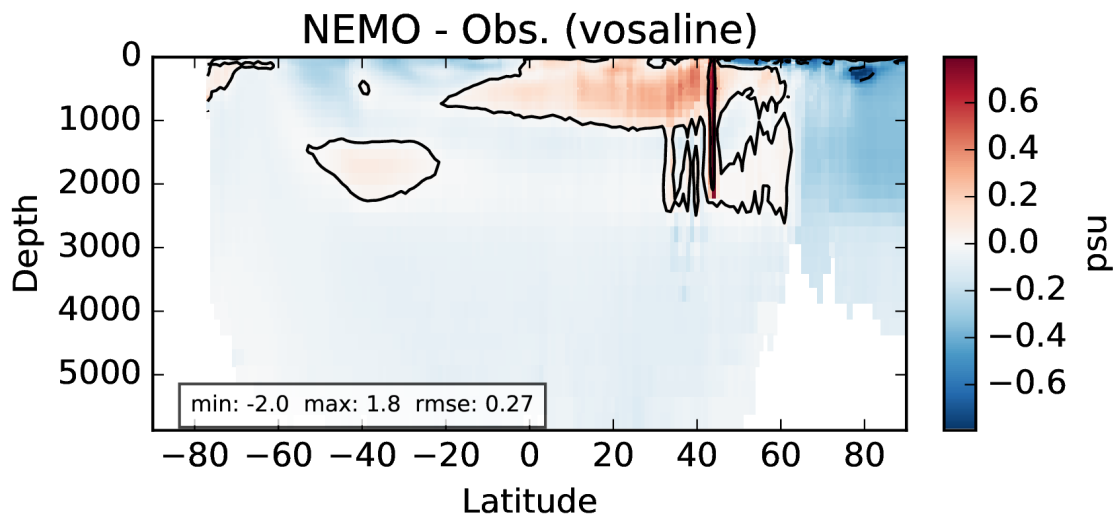
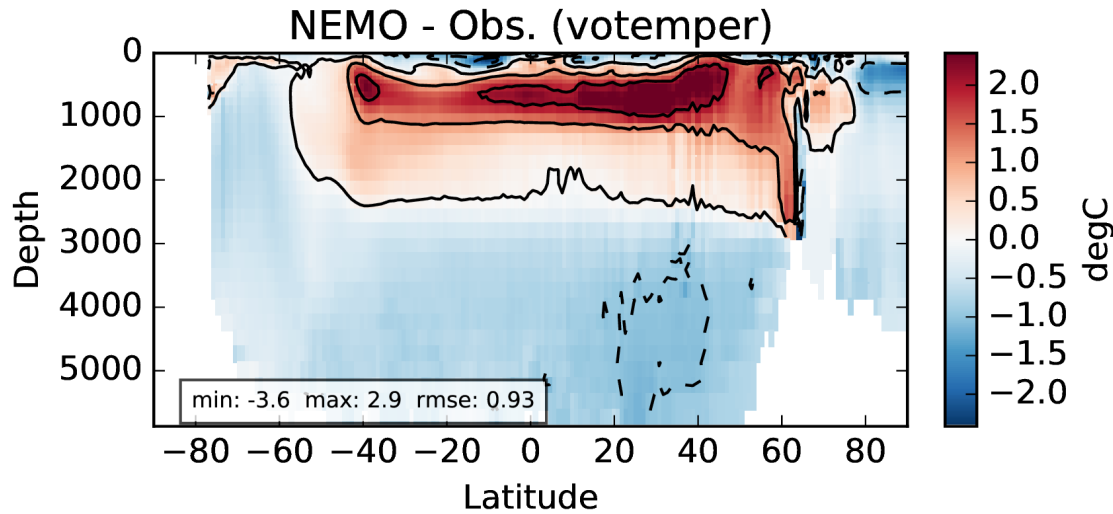

CanESM5 validation: ocean BGC

★ Obs. ● CanOE ● CMOC ● CanESM2 ● CanESM5

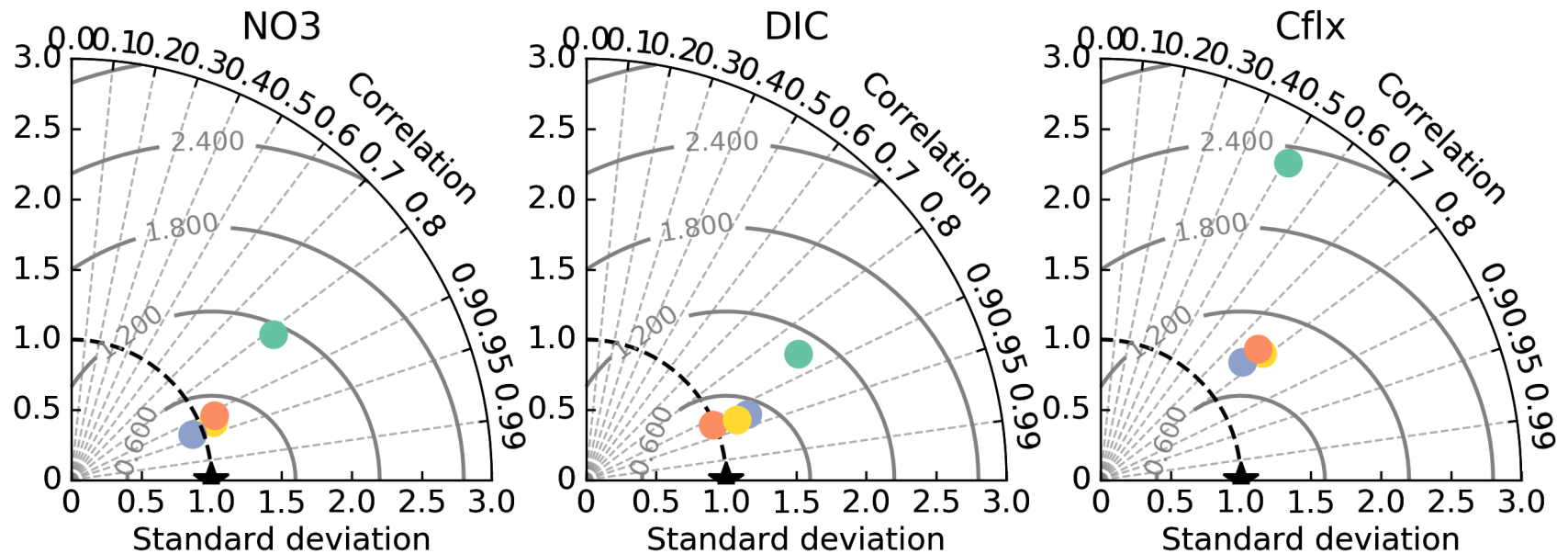

CanESM5 validation: ocean BGC

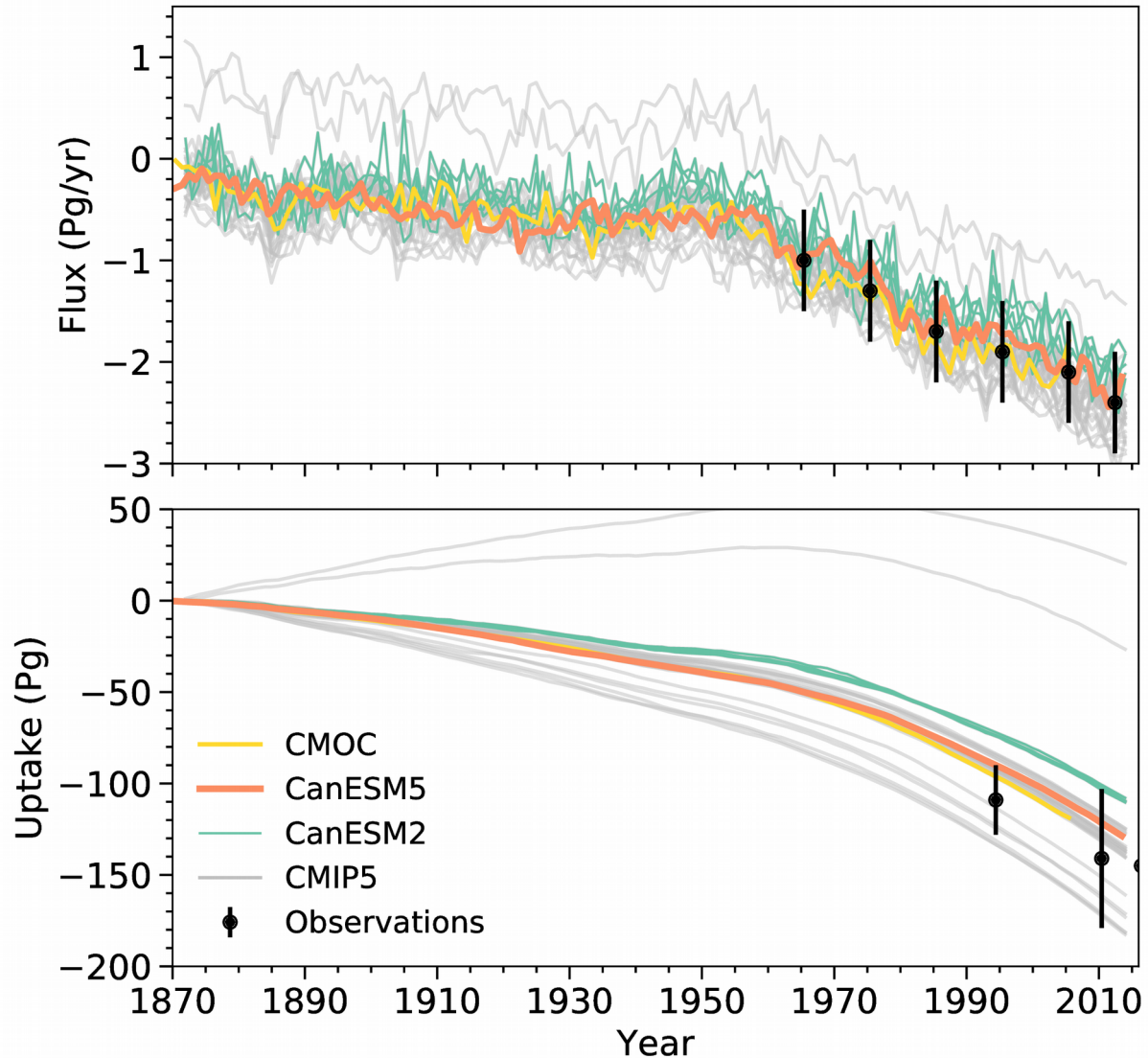

CanESM5 simulations for CMIP6

Annual screen temperature over globe

Annual 11-yr moving mean

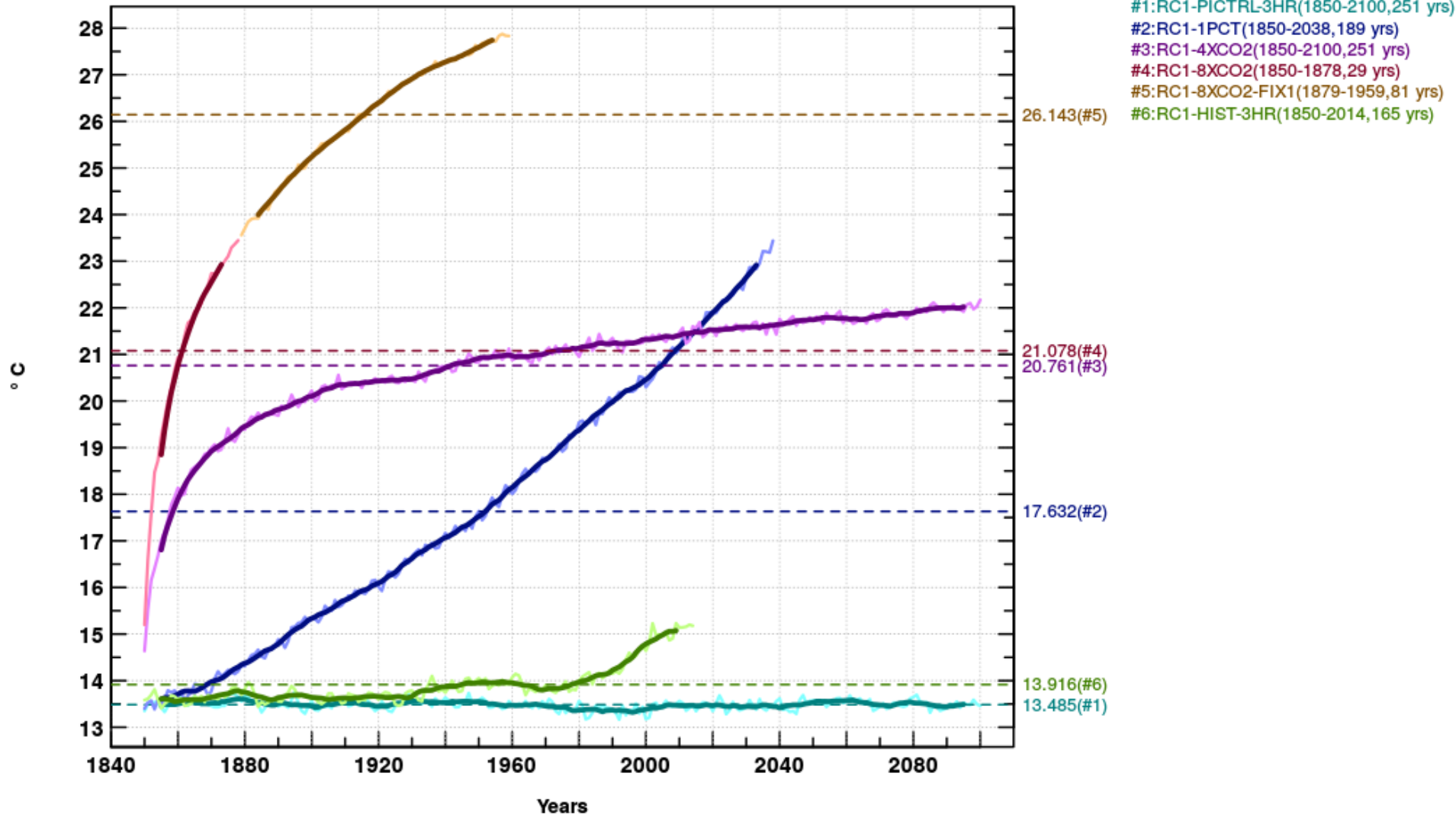

CanESM5 summary

- New version of CanESM, based on NEMO / LIM2
- Two biogeochemical models: CMOC & CanOE
 - CanOE and CMOC have similar skill at simulating large-scale distributions of DIC and nutrients, though differences exist locally.
- Preliminary CMIP6 simulations show
 - Improvement in skill over CanESM2, especially for BGC.
 - Fairly high climate sensitivity $O(5K)$
 - Cold bias in the Arctic. Too much heat in the thermocline.



CanCPL exchanges

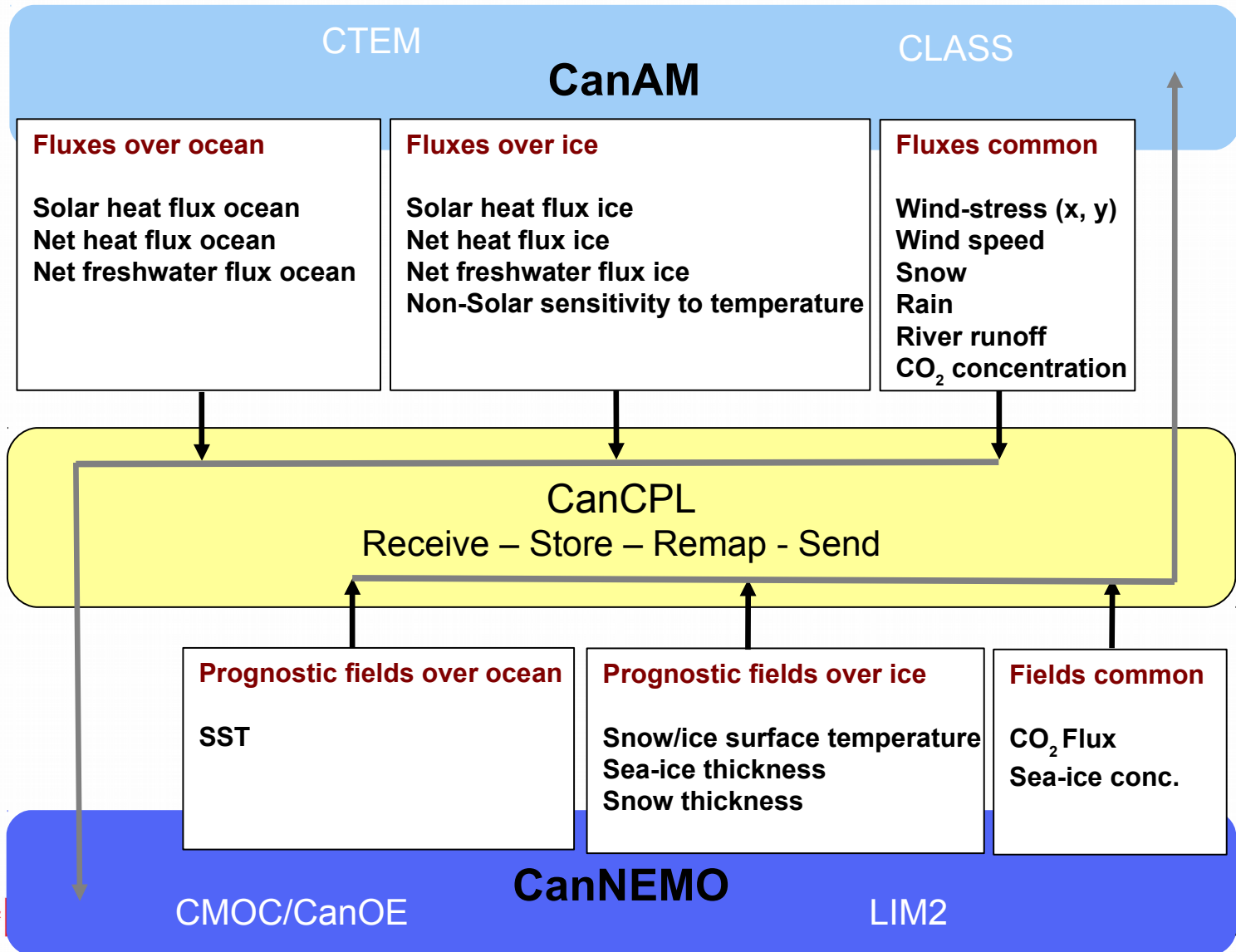

Drake Passage transport

#1

